

PLAN ON ROOF BETWEEN GRID F & H

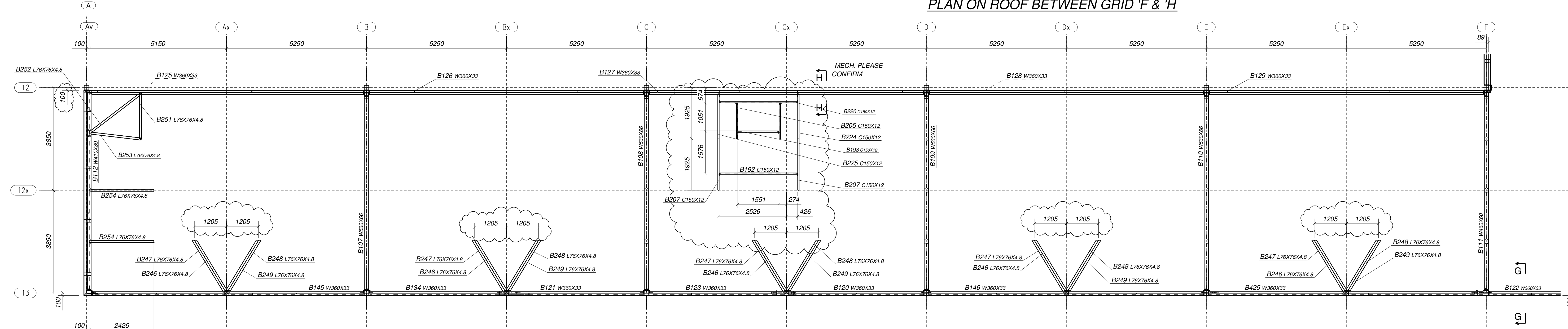

PLAN ON ROOF BETWEEN GRID 12 & 13

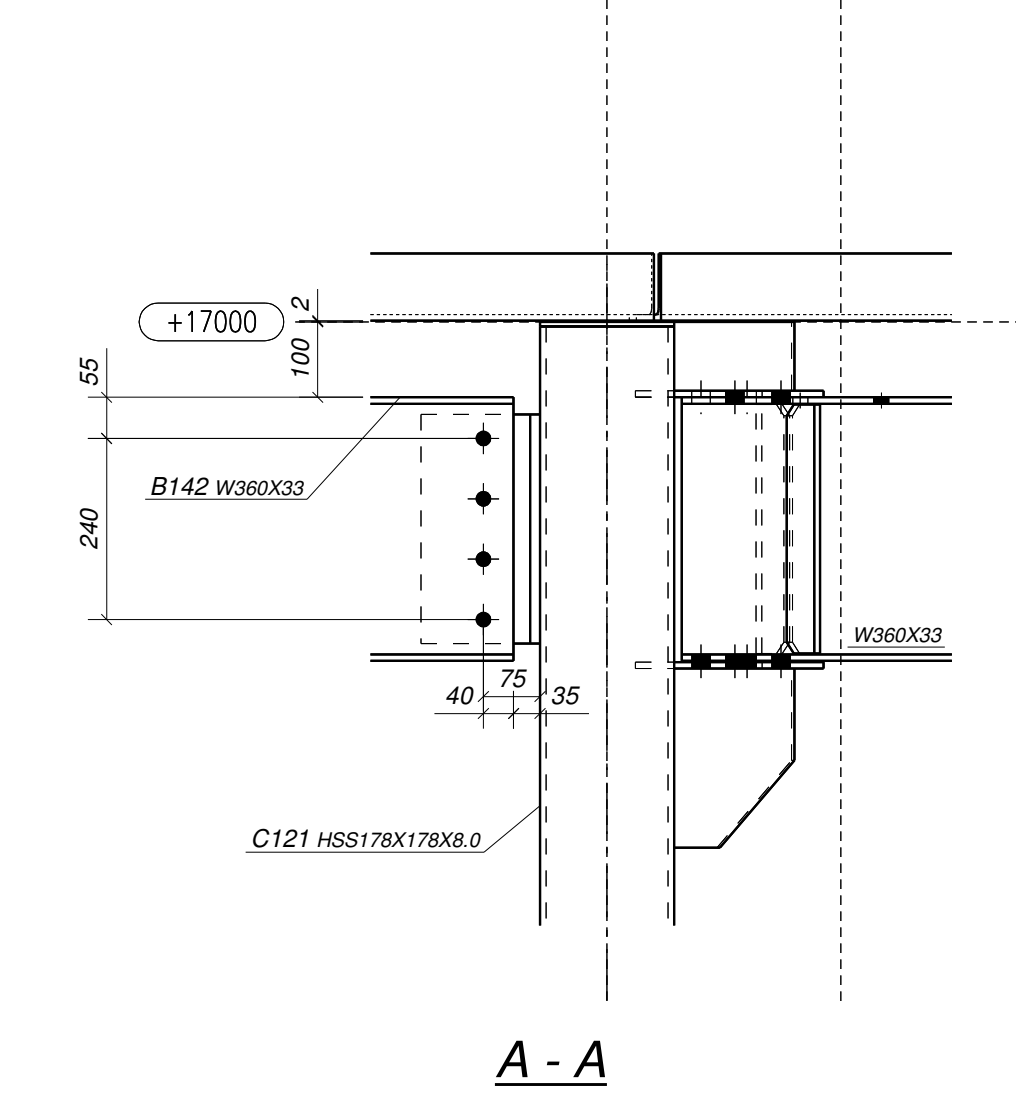

A - A

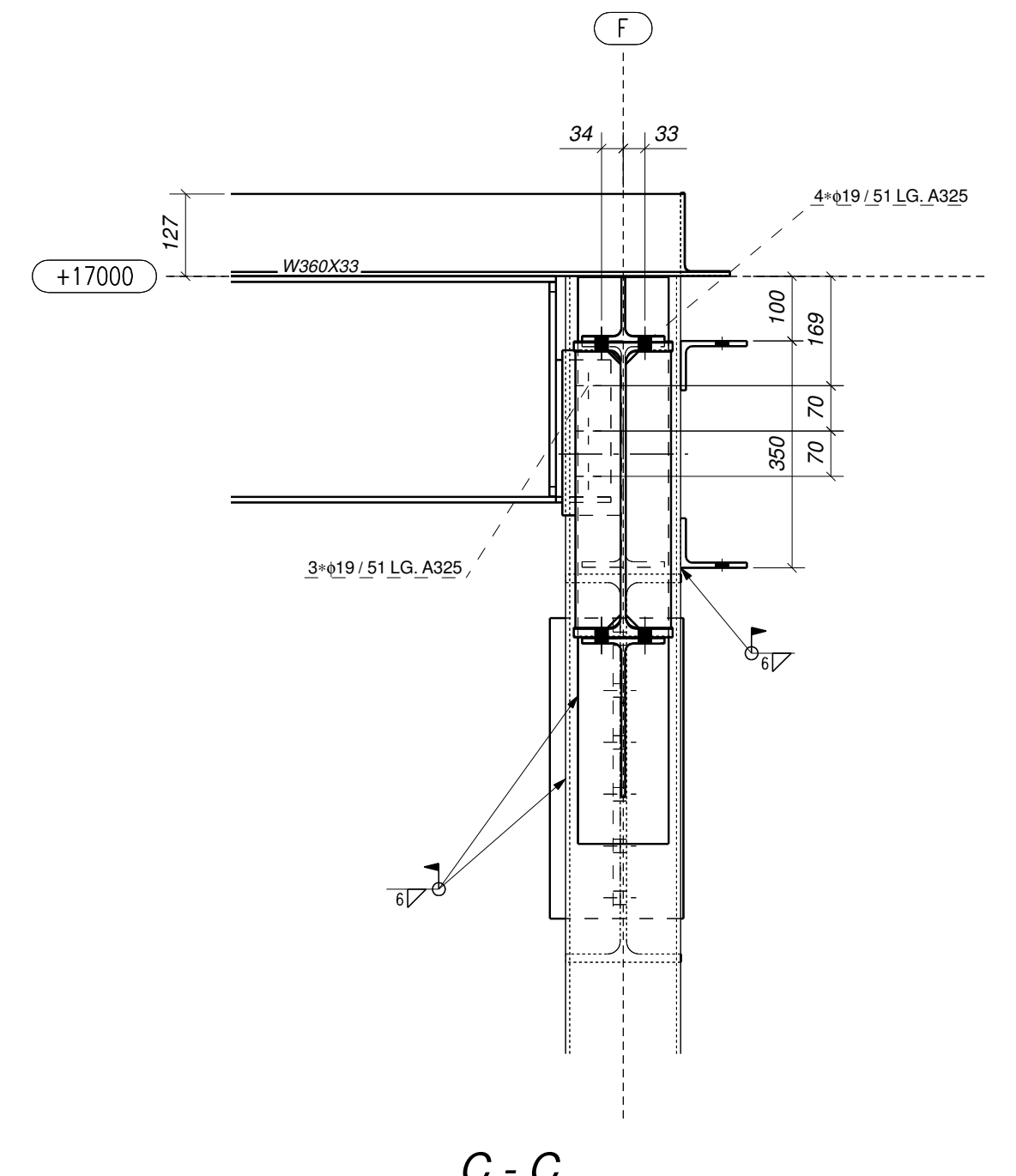

C - C

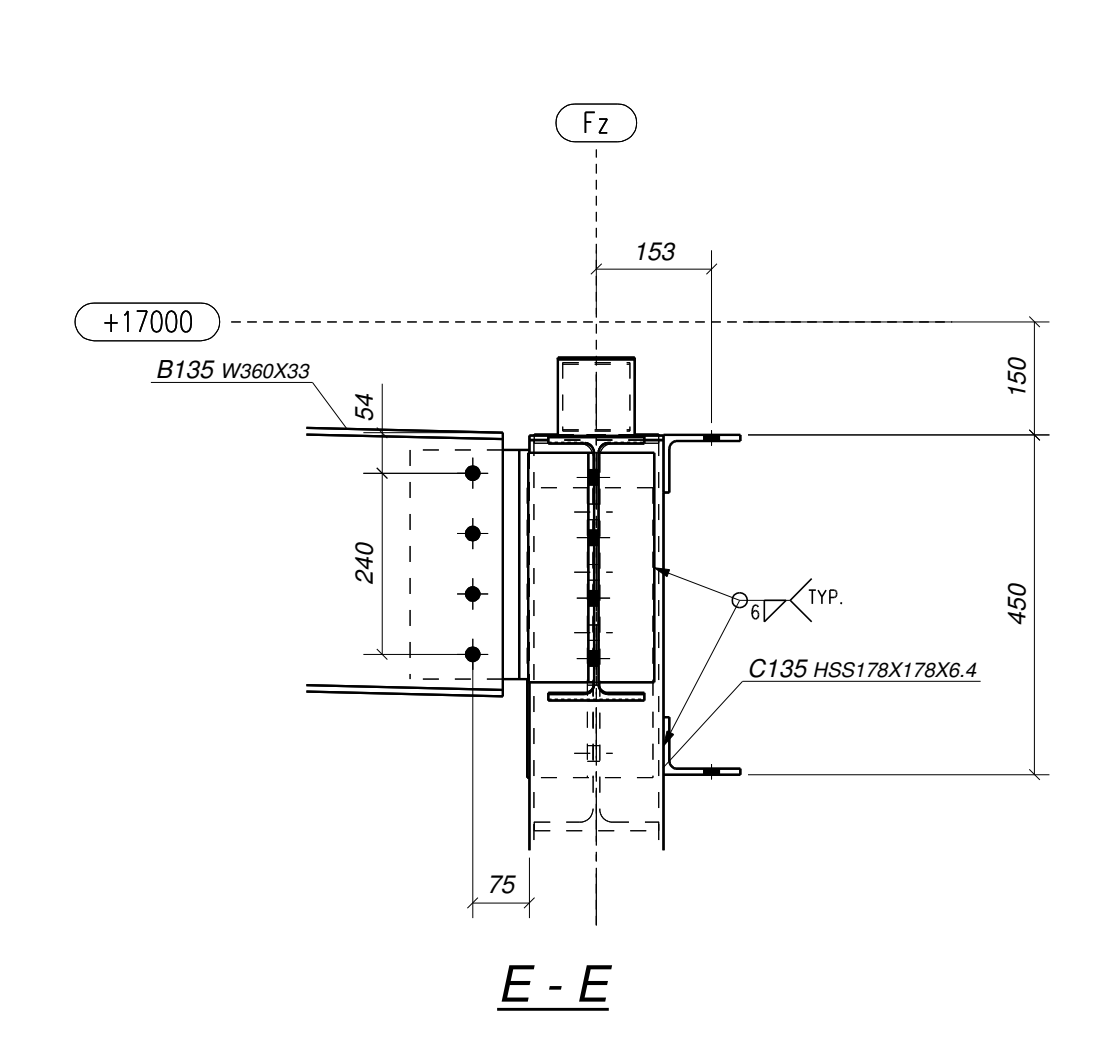

E - E

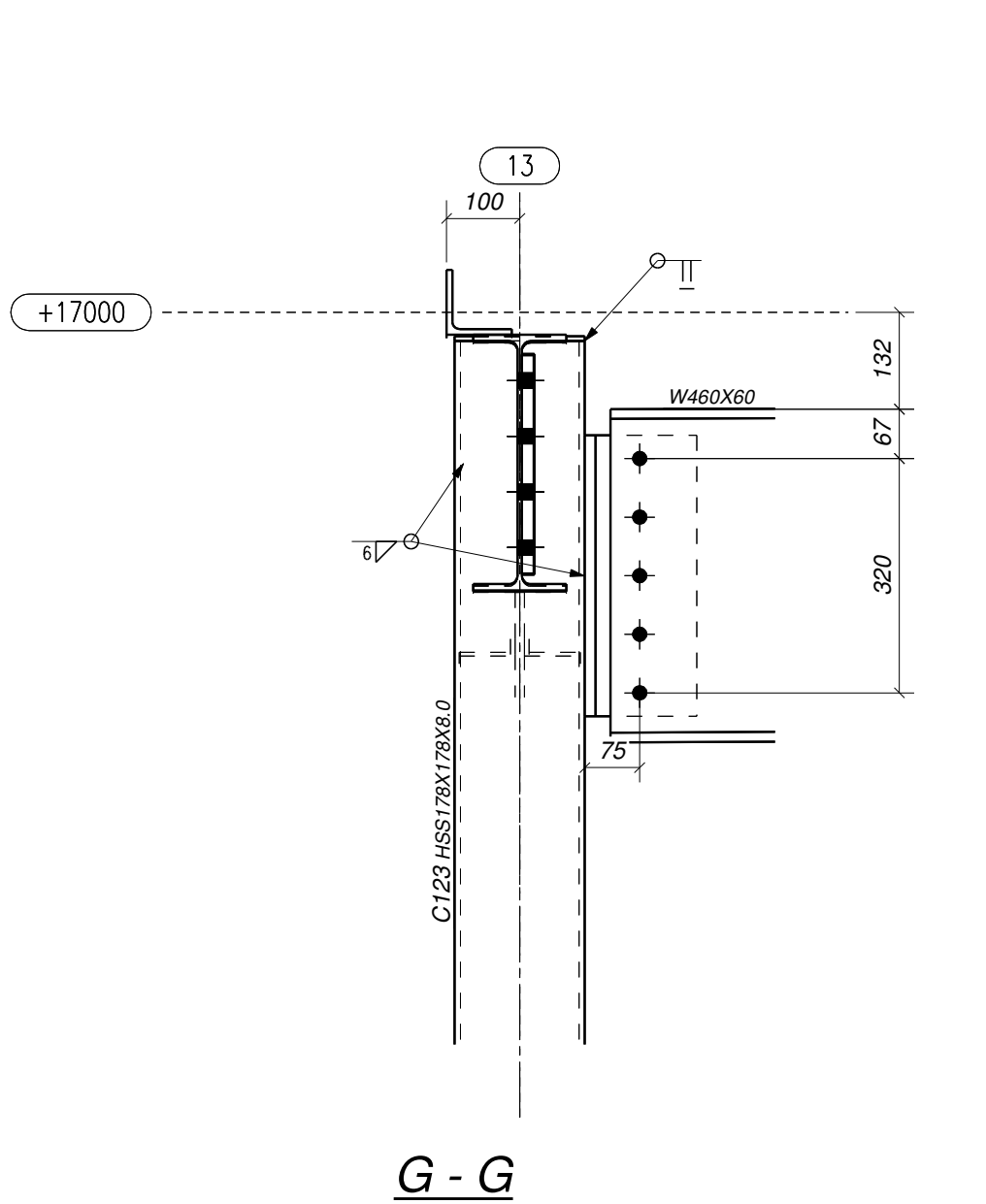

G - G

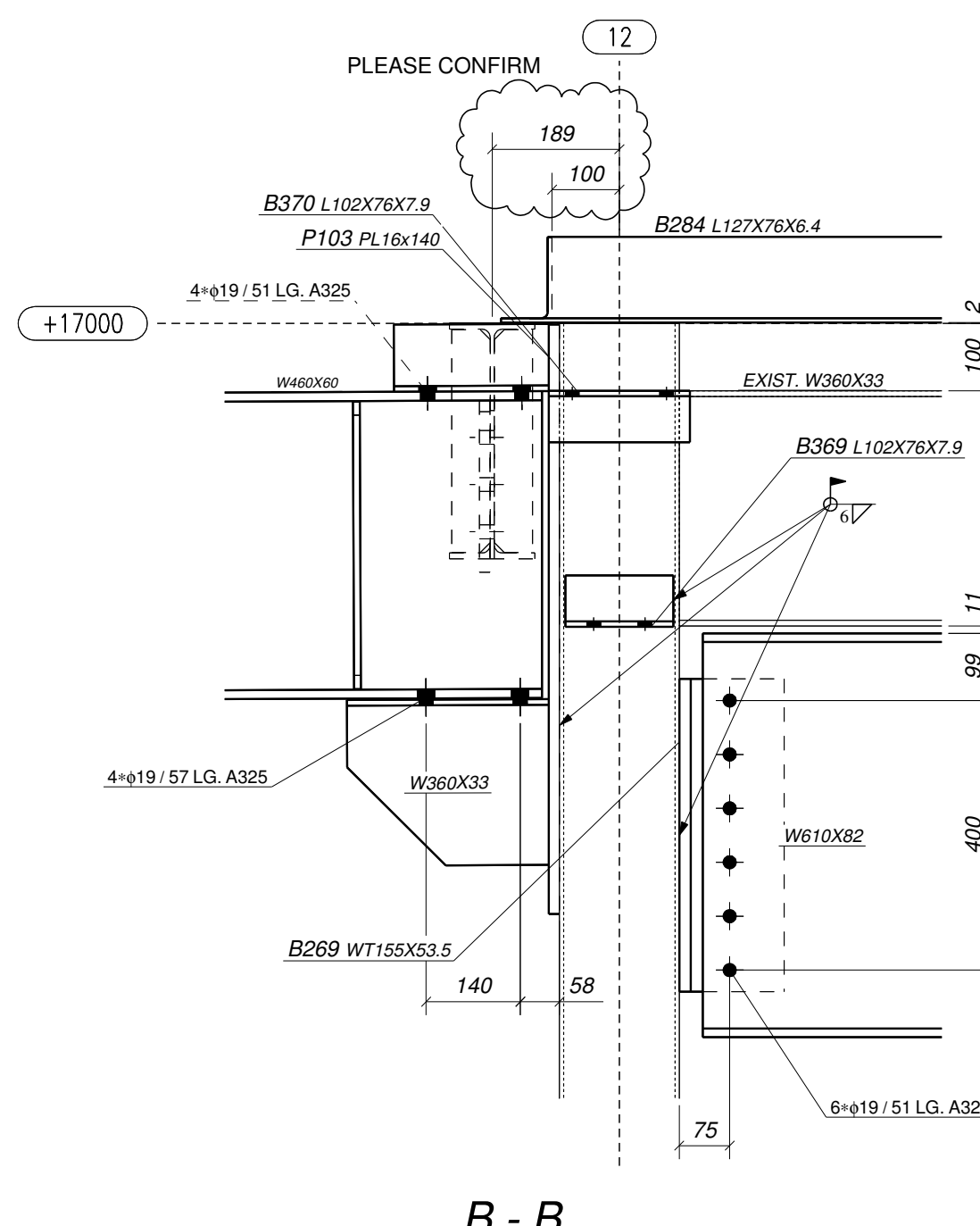

B - B

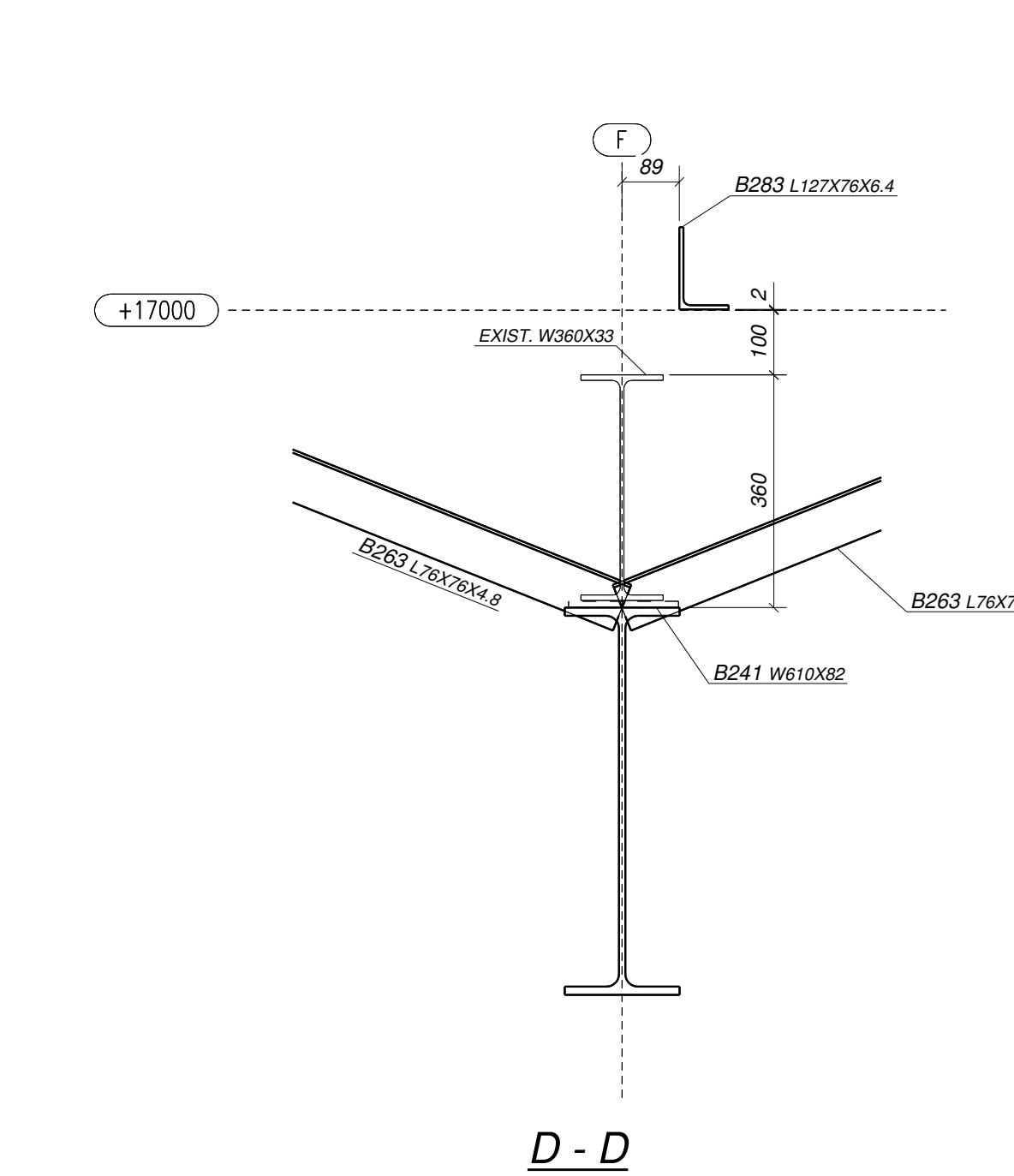

D - D

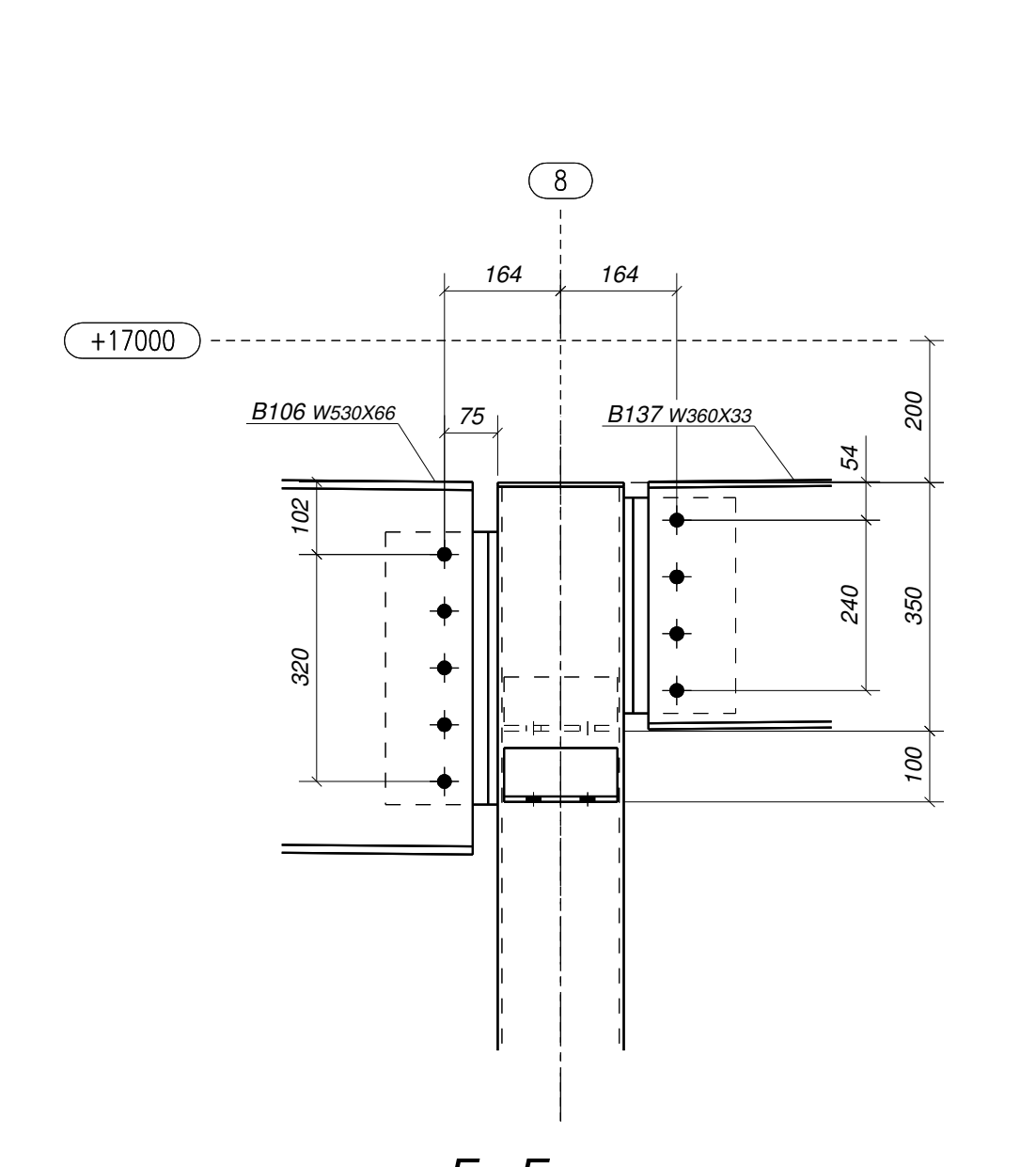

F - F

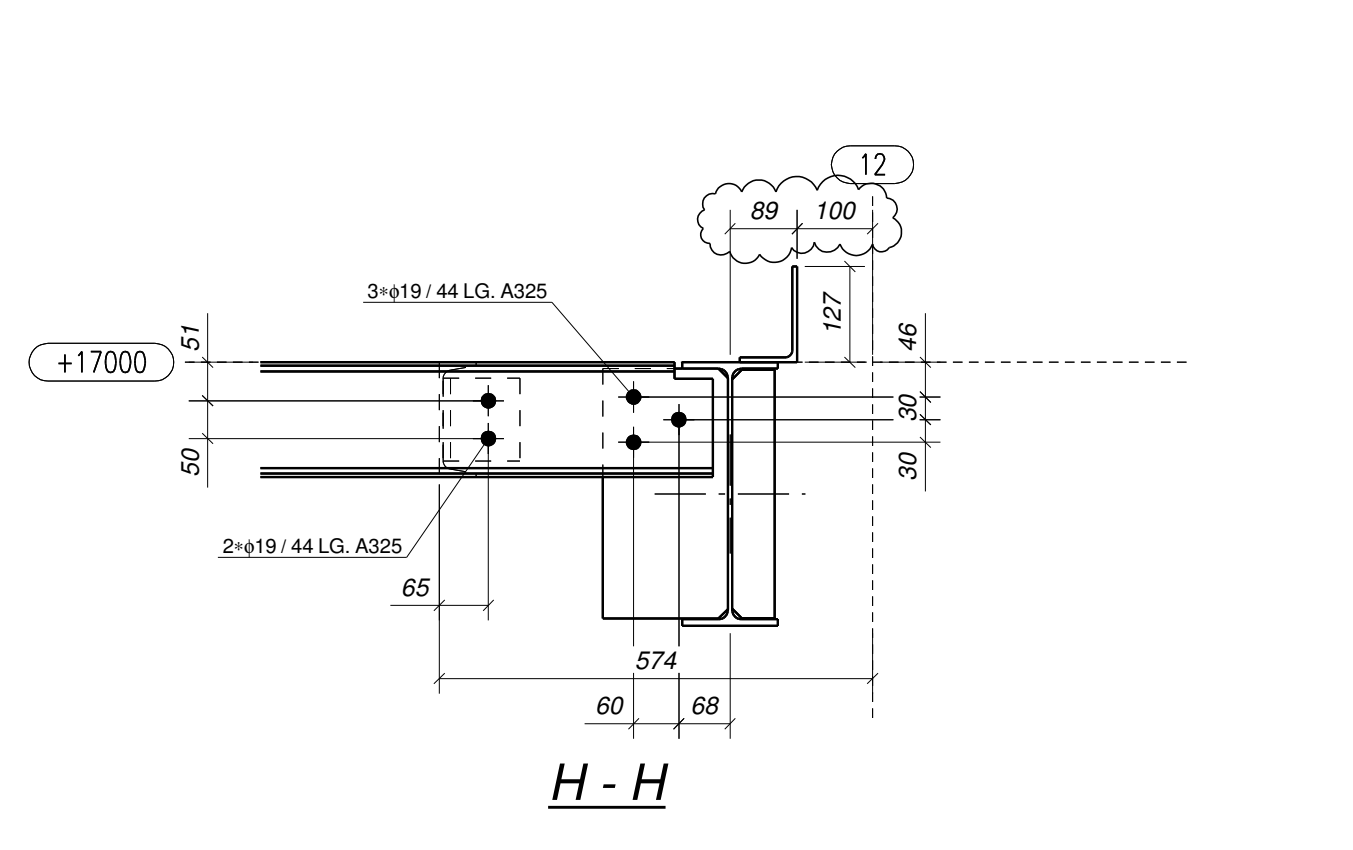

H - H

2007-06-19	LOCATION OF NEW W410x29 REVISED
2007-06-15	DISTANCE BETWEEN GRID LINE Av AND Ax CHANGED
2007-05-16	RE-IF-A; PART MARK CHANGED
2007-03-26	ISSUED FOR APPROVAL
SHOP PRINT	
NO BACK CHARGES WILL BE ACCEPTED WITHOUT PRIOR AUTHORIZATION IN WRITING	
NO I.E.	
BELAIR FABRICATION LTD. 1811 16th Avenue, White Rock, BC V4B 4S6 Phone: 250-244-0200, Fax: 250-244-0201	
CLIENT: RETAIL STORE & SERVICE CENTRE 1811 16th Avenue, White Rock, BC V4B 4S6	ARCH: Quinn Young Architects Ltd. 201 First Street S.E., Calgary, Alberta 403-243-1111
DRAWN BY: W. J. G. / M. J. G. CHECKED BY: L. K.	DATE: 06/15/2007 PROJECT: KW0025 DRAWING NO.: E101